

ZIGGY WIRELESS SHOWCASE

Surface Mounted Luminaires

WAC LIGHTING

Project Name:

Type:

Product Image

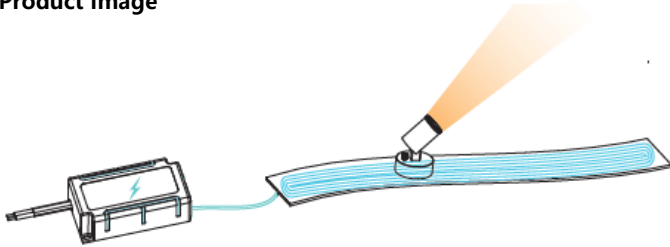

Line Drawing

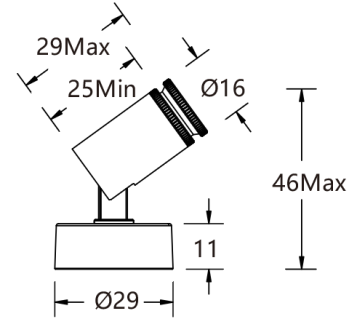

Product Description

ZIGGY Series LED wireless powered showcase light features a compact design. The system consists of a “transmitter strip” and a “showcase sensor luminaire”. The maximum distance between the transmitter tape and the fixtures is 10mm, without any metal or conductive material in between. It is recommended that 4 or less fixtures be installed per transmitter strip. This product can be used in museum and art gallery display cases.

Product Features

- **Body Material:** The transmitter belt is made of metal coil and wrapped with belt (thickness 3.2mm); the fixture is made of pure aluminum alloy body + plastic receiver base.
- **Optical System:** Focusing Lens
- **Finish:** Electrostatic Powder Coating, Black (BK), White (WT)
- **Projection Direction:** Vertical 0~90° adjustable, horizontal non-adjustable
- **Accessory/Bracket:** /
- **IP Rating:** IP20
- **Insulation Class:** Class III
- **Operating Temperature:** -20°C~40°C

Product Specification

- **LED Type:** High-Power LED
- **Source Power:** 1W
- **LED Lifetime:** >30000h-L70 / B10-Ta25°C(LM-80/TM-21)
- **CCT/CRI:** 3000K/4000K, Ra90 or Ra97(≥95) optional
- **Input:** 24VDC
- **Dimming:** No dimming (different installation position can change the brightness), knob dimming (optional)

Fixture Order Model

Model	LED	Dimming	Beam	CRI	CCT	Finish
AME19F ZIGGY	LD01 1W	E No-dimming	F 8-40°	9 Ra90	30 3000K	BK Black
				A Ra97	40 4000K	
ME19F	LD01	E	F	9	30	BK

Example: AME19FLD01-EF930BK

Transmitter Strip

Model	Length	Finish
AME19F ZIGGY	420 420*53*3.2, mm (L*W*H)	BK Black
	840 840*53*3.2, mm (L*W*H)	
AME19F	420	BK

Example: AME19F-420BK

Note: The fixture and the transmitting tape should be ordered separately. The length of the cable between the transmitter strip and the connected appliance is 500mm, and it should be connected by a quick-connect connector (the required hole is Φ16mm). The tape must not be bent, folded or modified. There must be no conductive objects within a 50mm radius. Consult WAC for details.

WAC Lighting
www.waclighting.com (US)
www.waclighting.net (International)

Headquarters
44 Harbor Park Drive • Port Washington, NY
Phone (516) 515.5000 • Fax (516) 515.5050

WAC Lighting(Shanghai)
14,Lane 299, Bi Sheng Road,Shanghai 201204
Phone (86.21) 3393.3558 • Fax (86.21) 3362.1598

WAC Lighting reserves the right to periodically design and update products.2025-01-09